



Internal Use Only

website:<http://biz.LGservice.com>

COLOR TV

SERVICE MANUAL

CHASSIS : CW81A

MODEL : 21FU3RL 21FU3RL-T3

CAUTION

BEFORE SERVICING THE CHASSIS,
READ THE SAFETY PRECAUTIONS IN THIS MANUAL.

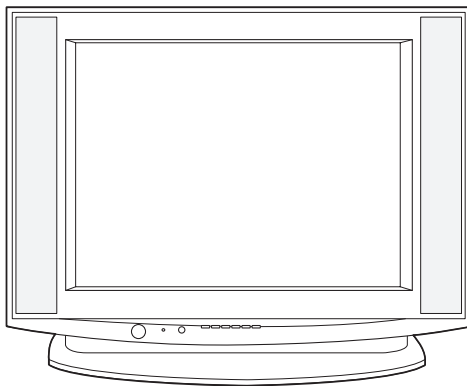

CONTENTS

Contents	2
Safety Precautions.....	3
Specifications.....	4
Adjustment Instructions.....	5
Trouble Shooting	8
Block Diagram.....	13
Exploded View.....	14
Exploded View Parts List	15
Replacement Parts List	16
SVC. Sheet.....	

SAFETY PRECAUTIONS

IMPORTANT SAFETY NOTICE

Many electrical and mechanical parts in this chassis have special safety-related characteristics. These parts are identified by \triangle in the Schematic Diagram and Replacement Parts List.

It is essential that these special safety parts should be replaced with the same components as recommended in this manual to prevent X-RADIATION, Shock, Fire, or other Hazards.

Do not modify the original design without permission of manufacturer.

General Guidance

An **isolation Transformer should always be used** during the servicing of a receiver whose chassis is not isolated from the AC power line. Use a transformer of adequate power rating as this protects the technician from accidents resulting in personal injury from electrical shocks.

It will also protect the receiver and its components from being damaged by accidental shorts of the circuitry that may be inadvertently introduced during the service operation.

If any fuse (or Fusible Resistor) in this TV receiver is blown, replace it with the specified.

When replacing a high wattage resistor (Oxide Metal Film Resistor, over 1W), keep the resistor 10mm away from PCB.

Keep wires away from high voltage or high temperature parts.

Due to high vacuum and large surface area of picture tube, extreme care should be used in **handling the Picture Tube**. Do not lift the Picture tube by its Neck.

X-RAY Radiation

Warning:

The source of X-RAY RADIATION in this TV receiver is the High Voltage Section and the Picture Tube.
For continued X-RAY RADIATION protection, the replacement tube must be the same type tube as specified in the Replacement Parts List.

To determine the presence of high voltage, use an accurate high impedance HV meter.

Adjust brightness, color, contrast controls to minimum.

Measure the high voltage.

The meter reading should indicate

23.5 \pm 1.5KV: 14-19 inch, 26 \pm 1.5KV: 19-21 inch,

29.0 \pm 1.5KV: 25-29 inch, 30.0 \pm 1.5KV: 32 inch

If the meter indication is out of tolerance, immediate service and correction is required to prevent the possibility of premature component failure.

Before returning the receiver to the customer,

always perform an **AC leakage current check** on the exposed metallic parts of the cabinet, such as antennas, terminals, etc., to be sure the set is safe to operate without damage of electrical shock.

Leakage Current Cold Check(Antenna Cold Check)

With the instrument AC plug removed from AC source, connect an electrical jumper across the two AC plug prongs. Place the AC switch in the on position, connect one lead of ohm-meter to the AC plug prongs tied together and touch other ohm-meter lead in turn to each exposed metallic parts such as antenna terminals, phone jacks, etc.

If the exposed metallic part has a return path to the chassis, the measured resistance should be between 1M Ω and 5.2M Ω .

When the exposed metal has no return path to the chassis the reading must be infinite.

An other abnormality exists that must be corrected before the receiver is returned to the customer.

Leakage Current Hot Check (See below Figure)

Plug the AC cord directly into the AC outlet.

Do not use a line Isolation Transformer during this check.

Connect 1.5K/10watt resistor in parallel with a 0.15 μ F capacitor between a known good earth ground (Water Pipe, Conduit, etc.) and the exposed metallic parts.

Measure the AC voltage across the resistor using AC voltmeter with 1000 ohms/volt or more sensitivity.

Reverse plug the AC cord into the AC outlet and repeat AC voltage measurements for each exposed metallic part. Any voltage measured must not exceed 0.75 volt RMS which corresponds to 0.5mA.

In case any measurement is out of the limits specified, there is possibility of shock hazard and the set must be checked and repaired before it is returned to the customer.

Leakage Current Hot Check circuit

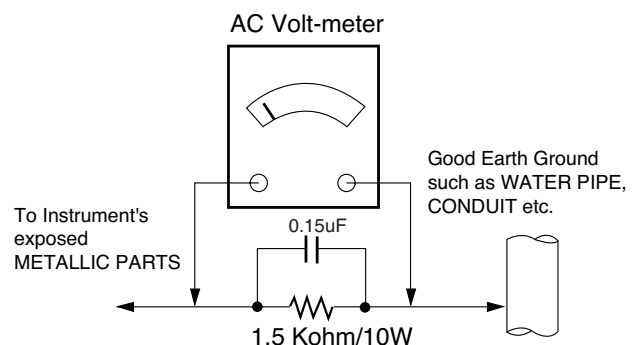

SPECIFICATIONS

Note : Specification and others are subject to change without notice for improvement.

1. Scope

This specification is applied to the CW81A Chassis.

2. Test and Inspection Method

- 1) performance : LGE TV test method followed.
- 2) Demanded other specification
 - Safety: CB Spec.(EN60065)
 - EMC: CE Spec.(EN55020,EN55013)

3. Test Condition

Each part is tested as below without special appointment

- 1) Temperature : $20 \pm 5^{\circ}\text{C}$ ($77 \pm 9^{\circ}\text{F}$), CST : $40 \pm 5^{\circ}\text{C}$
- 2) Relative Humidity : $65 \pm 10\%$
- 3) Power Voltage : Standard input voltage 220V, 50/60Hz
 - * Standard Voltage of each products is marked by models.
- 4) Specification and performance of each parts are followed each drawing and specification by part number in accordance with B.O.M.
- 5) The receiver must be operated for about 20 minutes prior to the adjustment.

4. General Specification

Item	Specification	Remark
Receiving System	PAL BG,DK,I / NTSC M(AV3.58/4.43)	China/ Indonesia/ Thai/ Vietnam
	PAL BG,DK,I / NTSC M(AV3.58/4.43) SECAM DK	CIS
	PAL BG,DK,I / NTSC M(AV3.58/4.43) SECAM BG,DK,L	Asia/ Middle East/ Africa
Available Channel	VHF : E2 ~ E12	
	UHF : E21 ~ E69	
	CATV : S1 ~ S20	
	HYPER : S21 ~ S41	
Input Voltage	220V~, 50/60Hz	East Asia
	100-240V~, 50/60Hz	Others
Market	China, Indonesia, Thai, Vietnam, Asia/Africa	
Screen Size	14 ~ 21 inch (Flat / Conventional)	
	21" Super slim/ultra slim	
Aspect Ratio	4:3	
Display Method	CRT	
Tuning System	FVS	
Operating Environment	1) Temp : 0 ~ 40 deg	
	2) Humidity : ~ 85 %	
Storage Environment	3) Temp : -20 ~ 60 deg	
	4) Humidity : ~ 90 %	

ADJUSTMENT INSTRUCTIONS

1. Application Object

These adjustment instructions are applicable to CW81A/B Chassis.

2. Notes

- (1) Because this is a cold chassis, it is not necessary to use an isolation transformer. However, operating it using a transformer between the power supply line and chassis input to prevent electric shock and to protect the test instrument.
- (2) All adjustments must be done in correct sequence. However, for better productivity, it can be changed in a pre-permitted range.
- (3) Environment conditions: If not specified, it must be done in following conditions.
 - 1) Temperature: $25\pm 5^{\circ}\text{C}$
 - 2) Humidity : $65\pm 10\%$
- (4) AC Voltage : $100\text{-}240\text{V} \pm 10\%$, 50/60Hz
- (5) If not specified, the receiver must be operated for more than 20 minutes prior to the adjustment.
- (6) Signal: Received the standard color signal. ($65\text{dB}\pm 1\text{dBuV}$)
PAL/SECAM : LG standard signal means the digital pattern
PAL_EU 05CH
- (7) If not specified, APC ON is APC CLEAR(DYNAMIC).

3. AGC Voltage Adjustment

3-1. Necessary Instrument

- : Digital Multi meter : 1 set
- Max Input Current : Over 1A/ Max Input Voltage : 500Vdc
 - Measurement Range : 10mV-100mVdc/ Accuracy : 0.03%

3-2. Adjustment Preparation

- 1) Input in the 75Ω cable 65dB($\pm 1\text{dB}$) LG standard signal.
- 2) Connect the multi-meter to J105(AGC Check Marking)

3-3. Adjustment

- (1) Press the "INSTART" key of factory remote control and select "VP0 (RF AGC)" adjustment mode.
- (2) Press the VOL +/- (◀▶)Key until the multi-meter shows reading as shown below.
- (3) CAUTION : Since the signal strength can be easily changed by the condition of signal cable , you need to check the signal strength frequently in order to prevent misadjustment.

4. Screen Voltage Adjustment

4-1. Adjustment (Use factory remote control)

- (1) Input in the 75Ω cable LG standard signal (Digital Pattern, 480NC)
- (2) Press the "ADJ" key of factory remote control once to make the TV set display horizontal line.
- (3) Turn the screen volume on the FBT clockwise until the horizontal line is visible and turn it counterclockwise until horizontal line faintly visible.
(Exit screen voltage adjustment by press "Enter(■)" key of factory remote control.)

5. Purity and Convergence Adjustment

5-1. Purity Adjustment

(1) Adjustment Preparation

- 1) Receive Red Raster Pattern for purity adjustment.(51ch)
- 2) Demagnetize the CPT and Cabinet with a degaussing coil.

(2) Adjustment

- 1) Pre-adjust the static convergence (STC) with the 4 and 6pole magnet.
- 2) If the horizontal Line is inline with CPT Mark, 2-Pole magnet should direct 3-9 o'clock direction
- 3) If not, direct 2-Pole magnet handle toward 6-12 o'clock direction and adjust the Horizontal Line to fall onto the mark opening the magnet at an angle.
- 4) Push the DY(deflection yoke) all the way to the CPT funnel.
- 5) Turn the purity magnet(2-pole magnet) so that the "green" color portion of left side and the "blue" color portion on the right side have equal amount of color.



<Fig. 1>

- 6) Pull the DY slowly backward and fix it when the whole screen becomes red. (The specified torque for fixing DY screw should be 10Kg/cm.)



<Fig. 2>

5-2. Convergence Adjustment

(1) Necessary Instrument

- 1) Degaussing Coil
- 2) Convergence fixing instrument (special tools)

(2) Adjustment Preparation

- 1) Operate the unit at the least 15 minutes before adjustment.
- 2) Using degaussing coil, remove the stains on CPT & Cabinet.
- 3) Received the Cross Hatch Pattern for Convergence (09ch).
- 4) Let the Contrast in normal luminance level.

(3) Static Convergence (STC) Adjustment

- 1) Receive Cross Hatch Pattern (09CH).
- 2) Before adjusting Static Convergence(STC),adjust the focus first seeing to it that the WHITE color picture quality is sharp enough.
- 3) Converge the RED vertical line and BLUE vertical line in unity(same line) by changing the angle between the 2 tabs of 4-pole magnet.
- 4) Converge the RED horizontal and BLUE horizontal line unity(same line) by turning the 2 tabs of the 4-pole magnet. At this time,do not change the angle between the 2 tabs.
- 5) Converge the R,G,B vertical line in unity(same line) by changing the angle between the 2 tabs of the 6-pole magnet.
- 6) Converge the R,G,B horizontal line in unity(same line) by turning the 2 tabs of the 6-pole magnet. At this time, do not change the angle between the 2 tabs.

(4) Dynamic Convergence (DYC) Adjustment

- 1) Y-Axis Adjustment : Adjust convergence of Y-axis (vertical) by moving the deflection yoke(DY) left and right.
- 2) X-axis Adjustment : Adjust convergence of X-axis (horizontal) by moving the deflection yoke(DY) up and down.

6. White Balance Adjustment

6-1. Necessary Instrument

- (1) Auto White Balance Meter (Low/High light Pattern generator)
- (2) CRT Color Analyzer, CA-100 : 1set
- (3) Factory Remote Control

6-2. Adjustment Preparation

: Prior to this adjustment, the Screen Voltage adjustment should be finished.

6-3. Auto Adjustment

- (1) Adjust the using Auto White Balance Meter.
- (2) Enter CPU OFF mode by press the "IN-START" & "MUTE" key of factory remote control in turn before adjustment. Exit CPU OFF mode by press the "MUTE" key of factory remote control after adjustment finished.
- * In case there is excess RED color at screen voltage adjustment, adjust it using "Volume -(▶)"Key of factory remote control until the RED color disappear.

6-4. Manual Adjustment

- (1) Adjust using white Balance meter and factory remote controller.
- (2) Enter into adjustment mode by pressing the INSTART key of factory remote control.
- (3) Use the CH▲, CH▼ Key to choose adjustment item.
- (4) Use the VOL◀, VOL▶ Key to change item data.

(5) Adjustment Procedure

- 1) Make the picture luminance 45Ft-L by change the "CONTRAST" and "BRIGHTNESS".
- 2) Adjust X data of high light with R DRIVE and Y data of high light with B DRIVE to have color temperature as shown below.
- 3) Make the picture luminance 4.5Ft-L by change the "CONTRAST" and "BRIGHTNESS".
- 4) Adjust X data of low light with R BIAS and Y data of low light with B BIAS to have color temperature as shown below.
- 5) Repeat steps a~d until both low and high light have same reading as shown below.

MARKET	COLOR TEMPERATURE	X-AXIS	Y-AXIS	REMARK
ALL	13000	268 ± 5	273 ± 5	

7. Focus Voltage Adjustment

This adjustment must be done after operating the TV set receiver sufficiently.

7-1. Adjustment Preparation

Received the LG standard pattern (PAL : Digital Pattern, 480NC, 13CH, NTSC : Crosshatch pattern, Ch.09) and set the picture condition on "APC ON" (CLEAR) mode.

7-2. Adjustment

Turn the focus volume on the FBT upper direction to have the best focus vertical line (figure 1.(a)) and horizontal line (figure 1.(b)) as shown below.

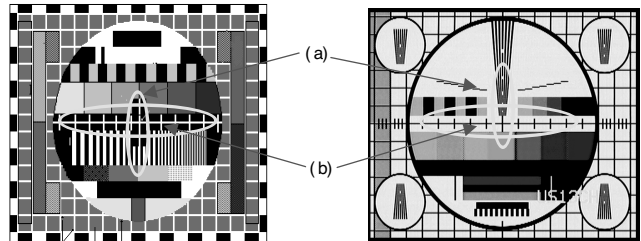

[figure 1-PAL]

[figure 1-NTSC]

8. SUB-BRIGHTNESS Adjustment

This adjustment must be done after the White balance Adjustment.

8-1. Adjustment preparation

- (1).NTSC
 - Received LG standard Mono scope pattern (CH14).
 - Set the picture condition on "APC ON" (CLEAR) mode.
- (2). PAL
 - Received PAL B/G 5CH pattern.
 - Set the picture condition on "PSM ON" (DYNAMIC) mode.

8-2 Adjustment

- (1) Press the "ADJ" key of the factory remote control twice to enter to "SUB-BRIGHTNESS" adjustment mode.
- (2) PAL MODEL : Change the Sub-Brightness data by pressing the VOL◀,VOL▶ KEY so that the 1th, 2th Black Level in gray scale of PAL B/G 05CH pattern have a little bit of difference. (See figure 2)

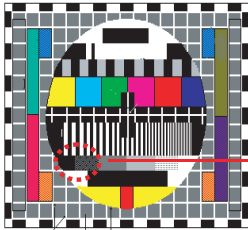

1th VS 2th
BLACK LEVEL have a little bit of difference.
(In case of VIETNAM MODEL 2th VS 3th)

[Fig.2] PAL B/G 05CH signal

8-3. Sub-Tint Adjustment

This adjustment has to be done only if the picture has bad tint otherwise, it can be omitted if the picture has good tint.

- (1) Received LG standard pattern signal (SMPTE, 2CH).
- (2) Set the picture condition on "APC ON" (CLEAR) mode.
- (3) Press the "ADJ" key of the factory remote control three times to enter to "SUB-TINT" adjustment mode.
- (4). Change the Sub-Tint data by pressing the VOL◀,VOL▶ Key until the upper and lower CYAN color becomes same color.

9. Deflection setting data adjustment

These adjustment will be done by Auto Adjustment Equipment.

For manual adjustment, it is also possible by the following procedure.

9-1. Adjustment Preparation

- (1) Deflection setting data adjustment can be done only with remote control.
- (2) Press the "INSTART" Key on the factory remote control continuously to enter to Deflection Adjustment mode.
- (3) Press the CH▲, ▼Key to select adjustment item.
- (4) Press the VOL◀, ▶ Key to change the data.

9-2. Adjustment

- (1) Horizontal Position Adjustment
Select SVC02 (H-POS) and adjust so that the left and right vertical line are symmetrical as possible.
- (2) Vertical Position Adjustment
Select SVC02 (V-POS) and adjust so that the horizontal center line coincide with geometric horizontal center of the CPT.
- (3) Vertical Size Adjustment
Select SVC02 (VA) and adjust so that the middle circle of the Digital Pattern (480NC, 13CH) coincide with the effective screen of CPT.

9-3. Adjustment (21" Super Slim, Ultra S/S Model)

- (1) Vertical Position Adjustment
Select SVC02(V-POS) and adjust so that the horizontal center line coincide with geometric horizontal center of the CPT.
- (2) Vertical Linearity Adjustment.
Select SVC02(V-LIN) and adjust so that the size of the upper circle is alike with the one of the lower circle at LG standard pattern signal (PAL : EU05CH, NTSC : 13CH).
- (3) Vertical Size Adjustment.
 - 1) NTSC :Select SVC02(VA) and adjust so that the middle circle of the Digital Pattern (480NC, 13CH) coincide with the effective screen of CPT.
 - 2) PAL : Select SVC02(VA) and adjust so that the middle circle of the Digital Pattern (PAL B/G 5CH) has 6~7mm gaps from the effective screen of CPT.
- (4) Horizontal Position Adjustment
Select SVC02(H-POS) and adjust so that the left and right vertical line are symmetrical as possible.
- (5) Horizontal Size Adjustment
Select SVC02(EW WIDTH) and adjust so that the outer line of the left, right and the remotest grid will correspond to the effective boundary surface.(The remotest grid, NTSC: within 2.5 ~ 3.0 column, PAL: within 0 ~ 25%)
- (6) Parabola Adjustment
Select SVC02 (EW PARAB) and adjust so that the vertical line of the remotest grid at the left or right side of the screen will be parallel to the vertical line of the center of screen
- (7) Trapezoidal Adjustment
Select SVC02(EW TRAPE) and adjust so that the width of the upper part of screen is alike with the one of the lower part of screen.
- (8) EW UPCOR/ LOCOR Adjustment
Select SVC02(EW UPCOR, EW LOCOR) and adjust so that the vertical line in the four corners become straight line.
- (9) BOW Adjustment
Select SVC02(HP BOW) and adjust so that the vertical line in the four corners become straight line.

TROUBLE SHOOTING

1. TV FUNCTIONAL

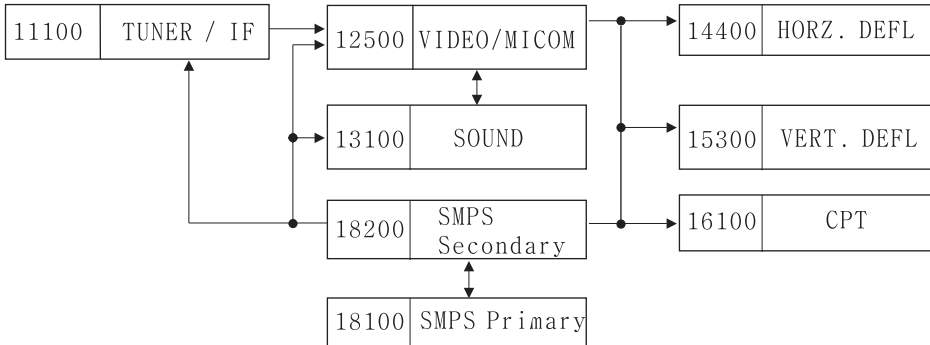

2 TU/IF SECTION

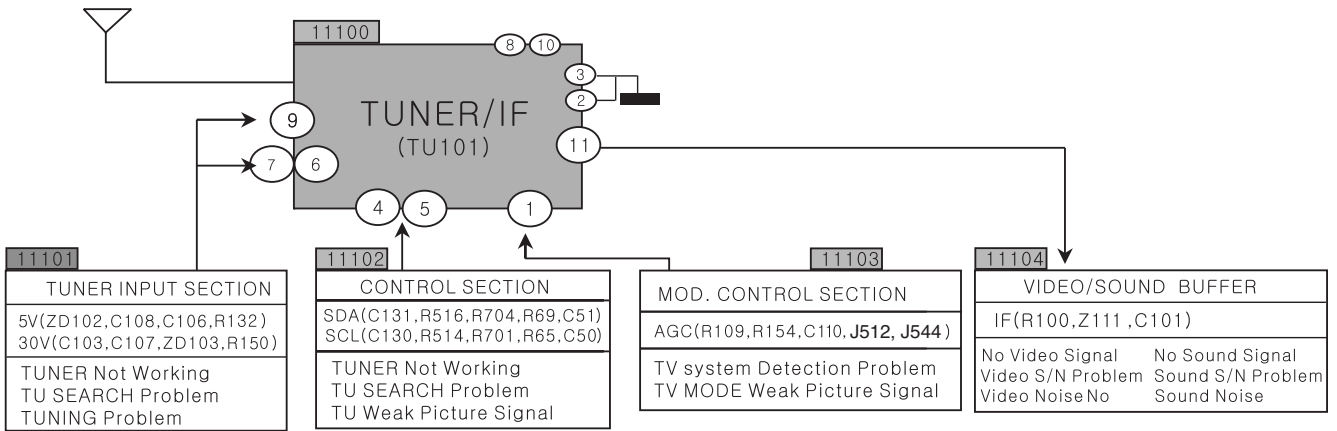

3. VIDEO PROCESSING

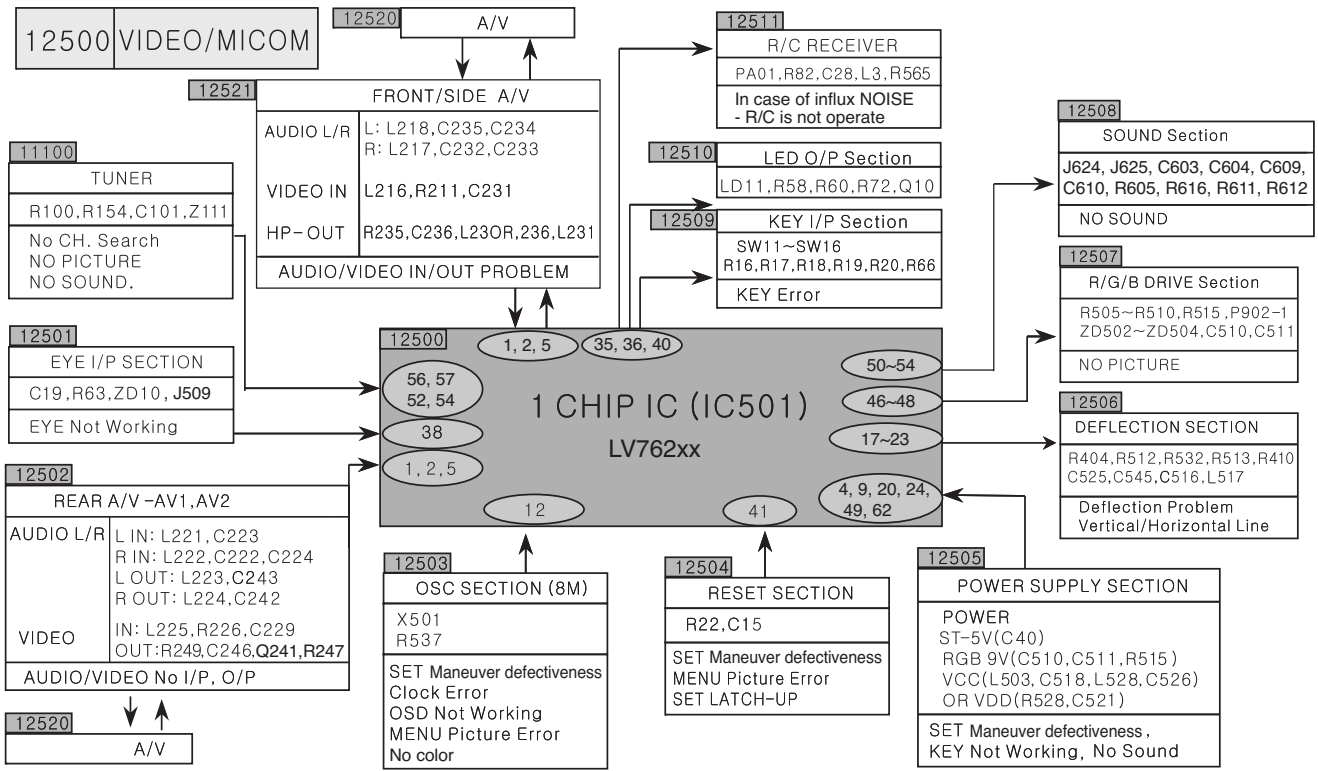

4. SMPS PRIMARY

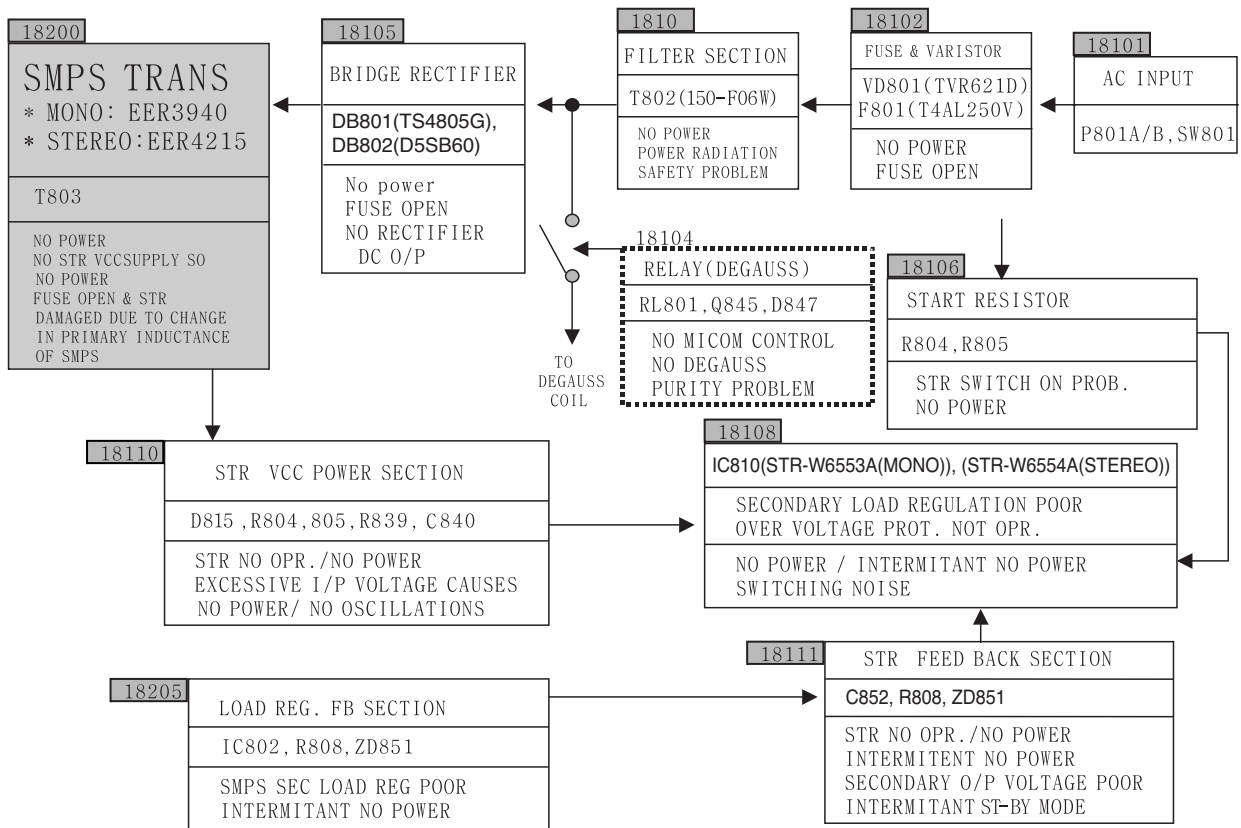

5. SMPS SECONDARY SECTION

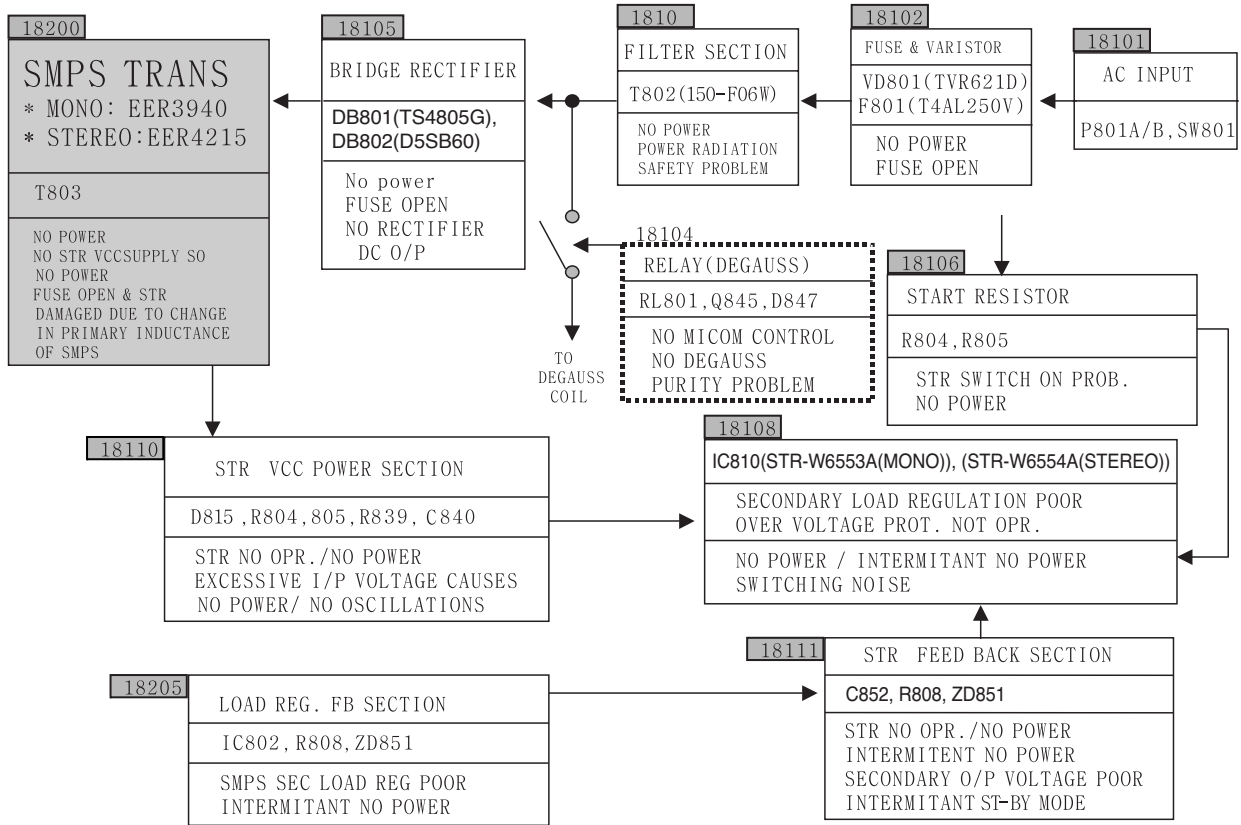

6. VERTICAL SECTION

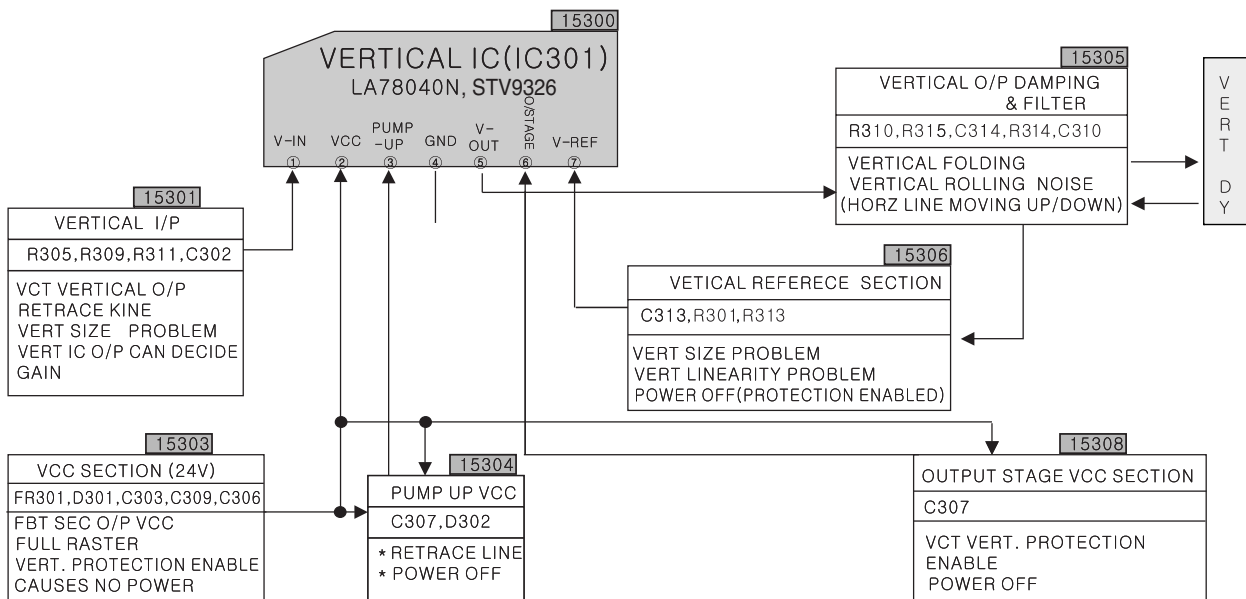

7. HORIZONTAL SECTION

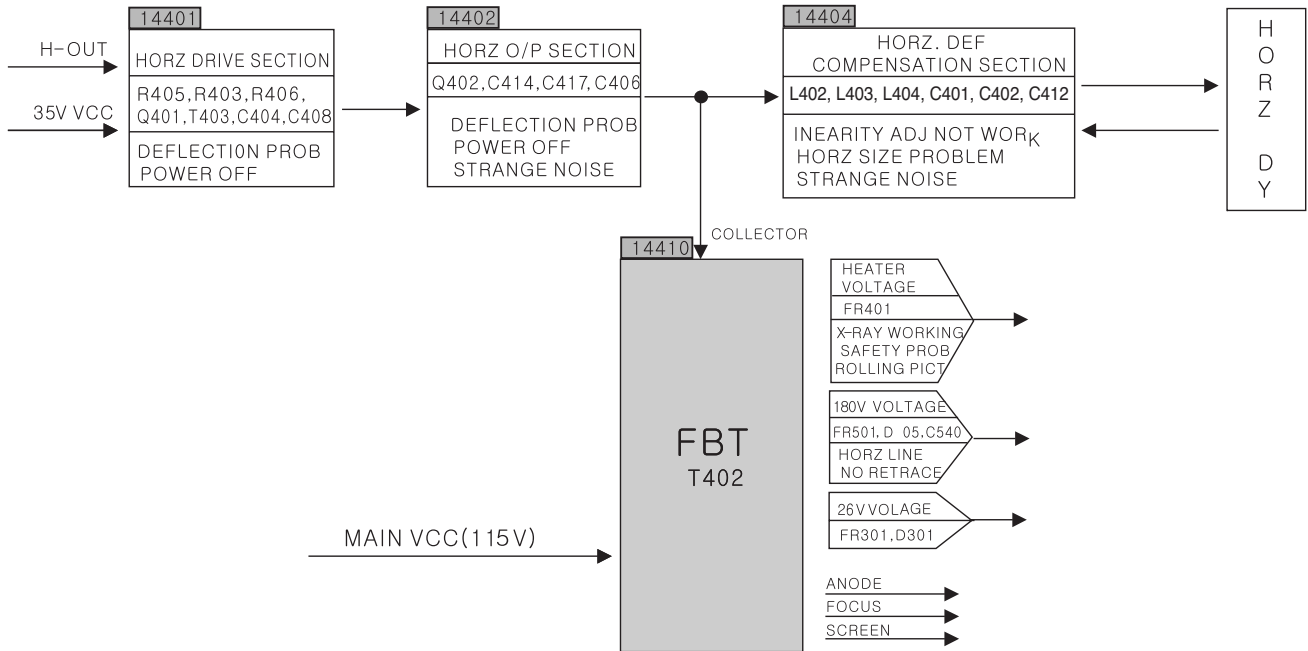

8. SOUND PROCESSING SECTION

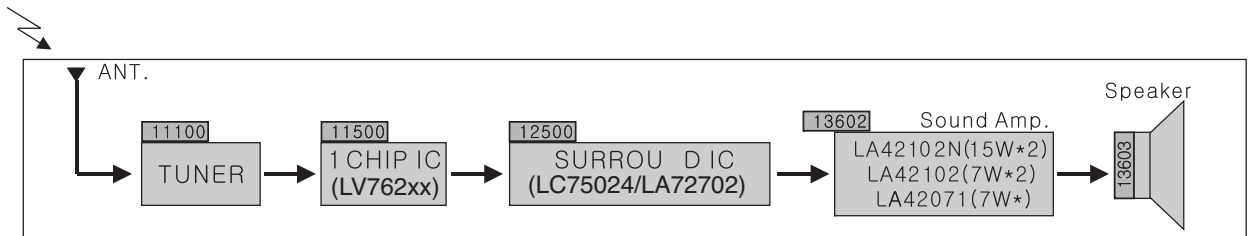

- TUNER : RF signal is feed to TUNER through Antenna. IF output from Tuner is then given to 1 CHIP IC.
- 1 CHIP IC : 1 CHIP IC processes the input IF. Demodulates Picture and sound information and gives analog RGB output for Display and SPKL/R as audio output, this sound output is further Amplified and feed to speakers.
- Sound Amp : Sound amps(LA42102N,LA42102,LA42071) is and Audio Amplifier it amplified the output sound signal from Surround ic(LA75024/LA72702) and feeds to speaker which generats Sound.

9. CPT DRIVE SECTION

CPT Board Circuit 16100

The CPT-BOARD assembly is composed of discrete type RGB Amplifier.
 Amp-Gain is defined by Resistance of R901, R911, R914 and R917, R912, R923
 High Frequency compensation is made by inductance of L901, capacitance of C907, C904 and C902.
 DC level of collector of Q901, Q902 and Q903 is defined by R904 & R905

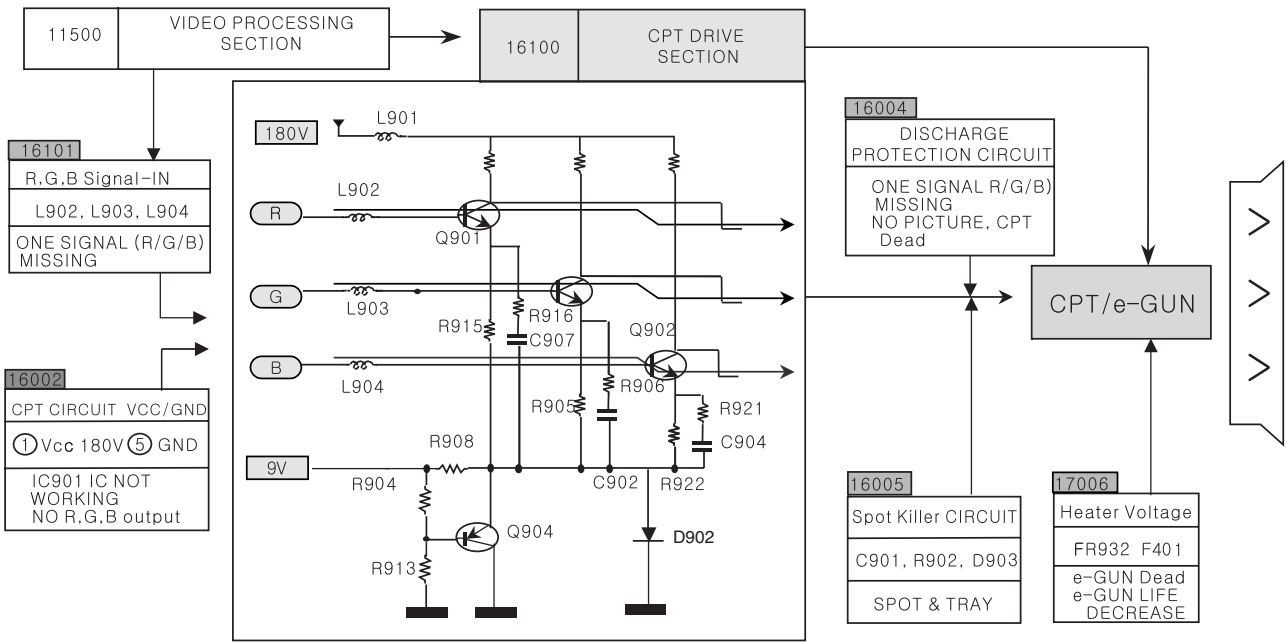
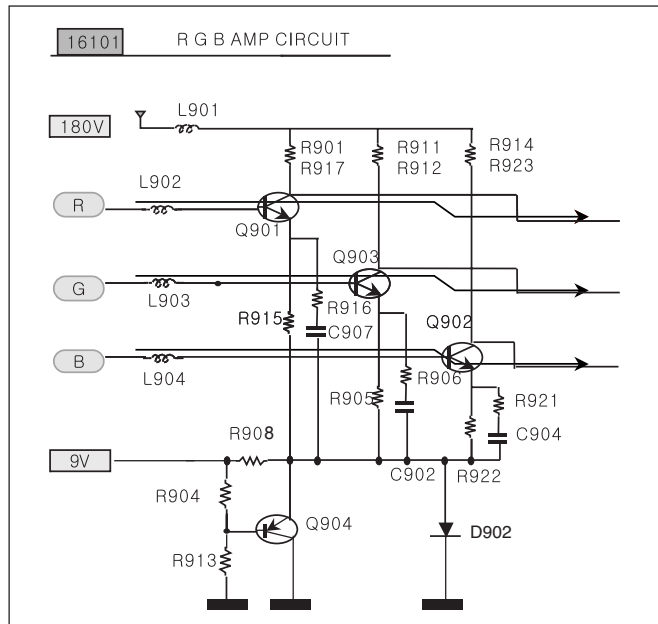

BLOCK DIAGRAM

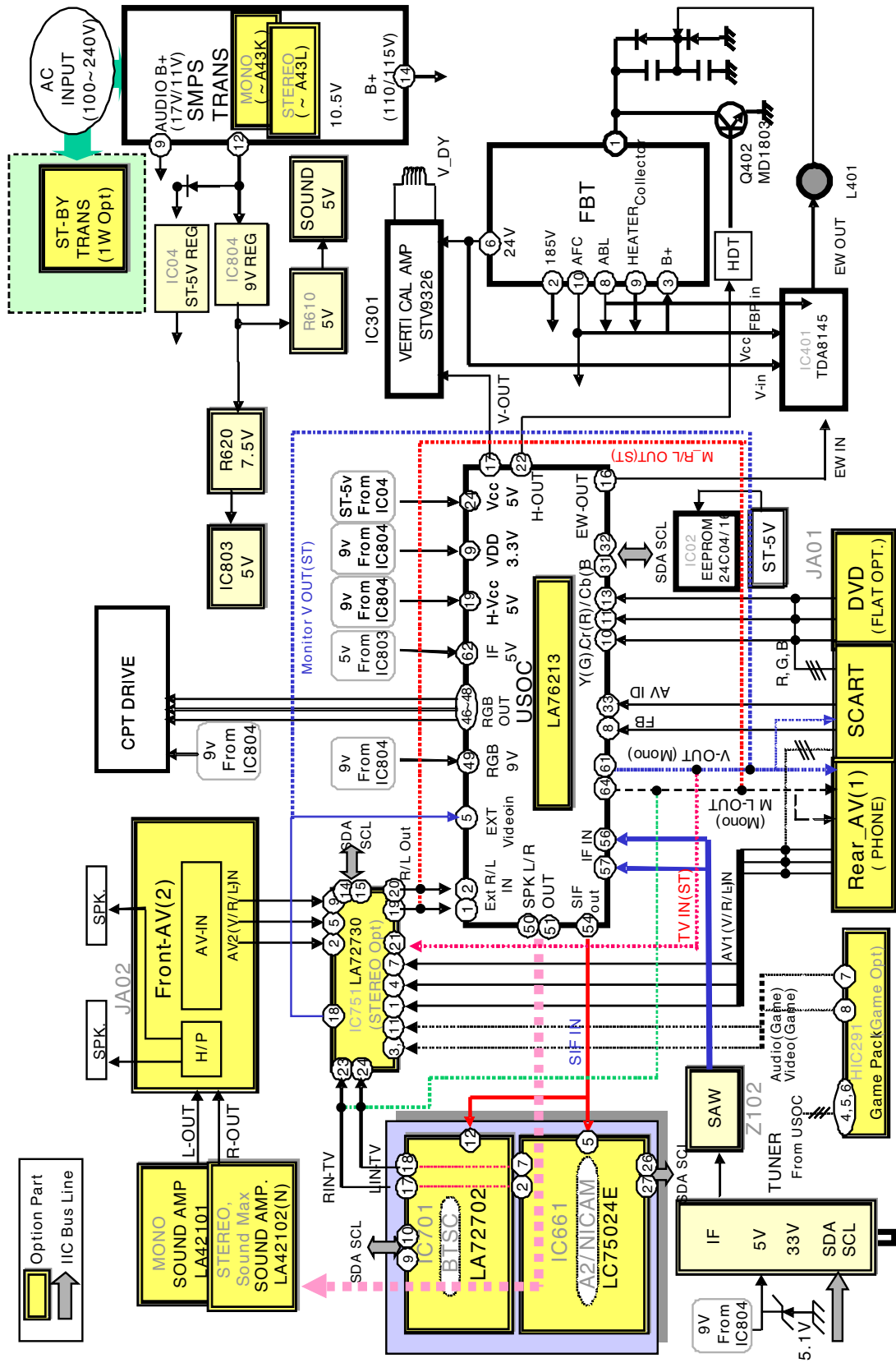

EXPLODED VIEW

IMPORTANT SAFETY NOTICE

Many electrical and mechanical parts in this chassis have special safety-related characteristics. These parts are identified by \triangle in the Schematic Diagram and EXPLODED VIEW. It is essential that these special safety parts should be replaced with the same components as recommended in this manual to prevent X-RADIATION, Shock, Fire, or other Hazards. Do not modify the original design without permission of manufacturer.

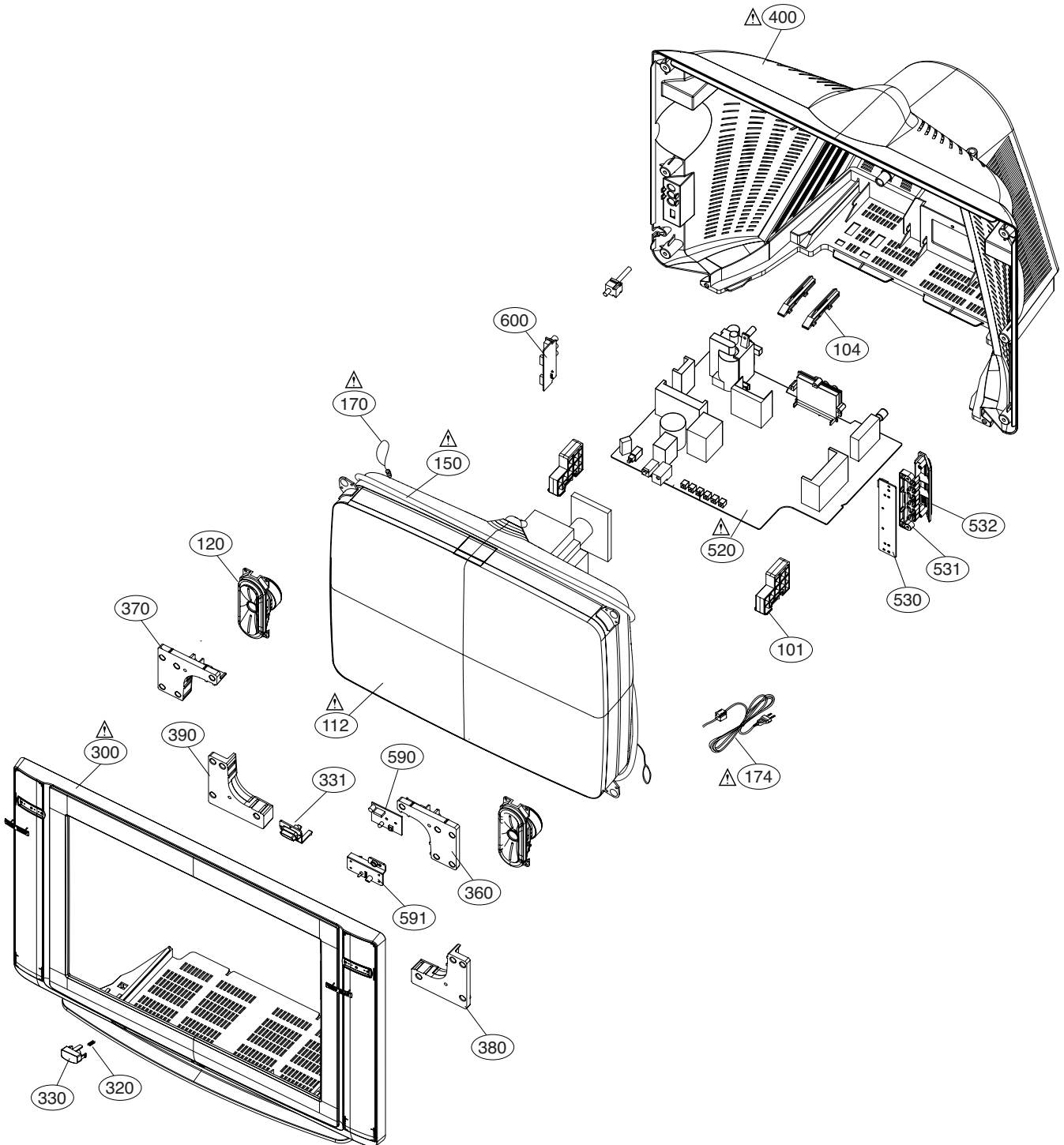

<SCHEMATIC DIAGRAM OF CW-81A>

VERSION 1.11 2008.02.26

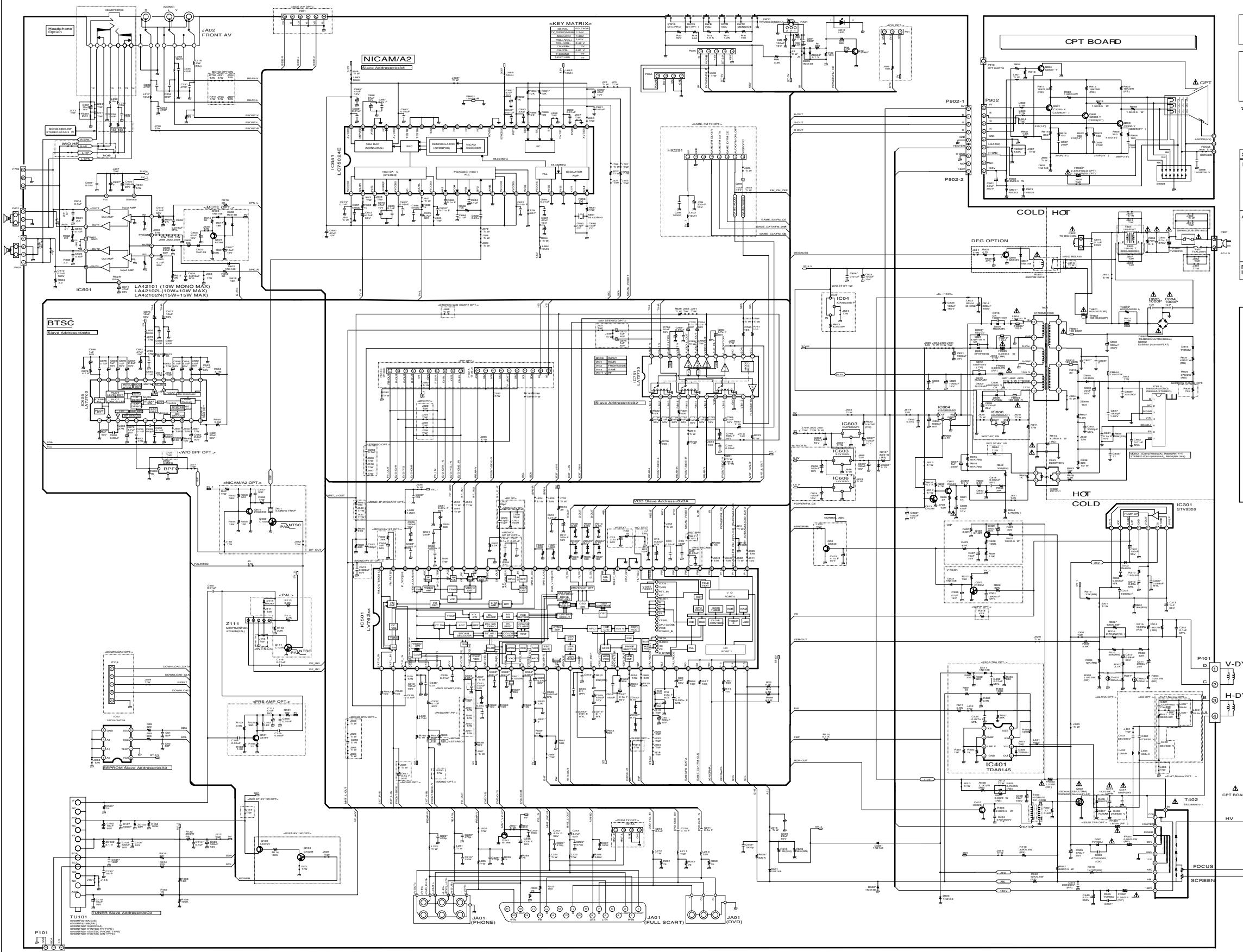

WARNING: BEFORE SERVICING THIS CHASSIS, READ 'X-RAY RADIATION PRECAUTION', 'SAFETY PRECAUTION' AND 'PRODUCT SAFETY NOTICE' IN THIS MANUAL.

CAUTION: THE MARKS IN THE SCHEMATIC DIAGRAM AND THE PARTS LIST DESIGNATE COMPONENTS WHICH HAVE SPECIAL CHARACTERISTICS FOR SAFETY, AND SHOULD BE REPLACED ONLY WITH TYPES IDENTICAL TO THOSE IN THE ORIGINAL CIRCUIT OR SPECIFIED IN THE PARTS LIST. BEFORE REPLACING ANY OF THESE COMPONENTS, READ CAREFULLY THE PRODUCT SAFETY NOTICE IN THIS MANUAL. DO NOT DEGRADE THE SAFETY OF THE RECEIVER THROUGH IMPROPER SERVICING.

* : OPTION
=>Initial model: 21"ULTRA S/S(21FU1R)
<IC VERSION>

SOUNDIC	SYSTEM	COMBEXTXT Surround			A2+NICAMBTSC	
		COM	EXT	XT		
MONO	LV76210	PAL/NT	X	X	X	
	LV76220	PAL/NT/SECAM	X	X	X	
	LV76230	PAL/NT/SECAM	X	X	X	
AV-ST	LV76211	PAL/NT	X	X	X	
	LV76221	PAL/NT/SECAM	X	X	X	
	LV76231	PAL/NT/SECAM	X	X	X	
	LV76212	PAL/NT	X	X	X	
	LV76222	PAL/NT/SECAM	X	X	X	
	LV76232	PAL/NT/SECAM	X	X	X	
RF-ST IC	LV76213	PAL/NT	X	X	X	
	LV76223	PAL/NT/SECAM	X	X	X	
	LV76233	PAL/NT/SECAM	X	X	X	
LA75024	A2/NICAM				X	
LA7202N	BTSC					X

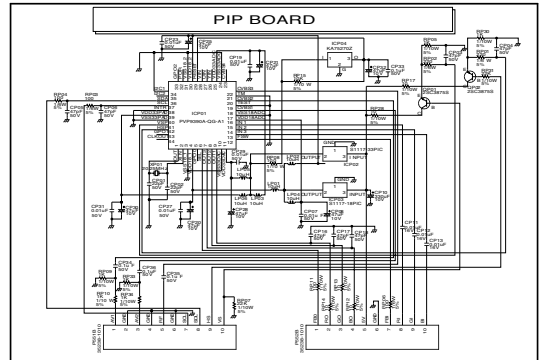



P/NO : MFL41322905

May, 2008
Printed in Korea

